

Rotating Torque Sensor DR-2500 (contactless) with Nominal Torque from 0.005 ... 150 N·m



This sensor has a contactless and digital signal transmission from rotor to stator without signal falsification of the measurement data. It is therefore highly accurate and maintenance-free.

Performance Features

- Bearingless miniature sensor for e.g. test bench applications
- High accuracy
- Active output $\pm 5V$ (optional $\pm 10V$)
- Integrated speed measurement, optional
- Speed up to 30000 min^{-1}
- Very short axial length
- High torsional stiffness
- Simple handling and assembly
- Special versions on request

Application

- Research and development
- Process measuring and control technology
- Fully automated machining centres
- Measuring and control devices
- Tool engineering
- Special mechanical engineering

Dimensions of DR-2500 in mm

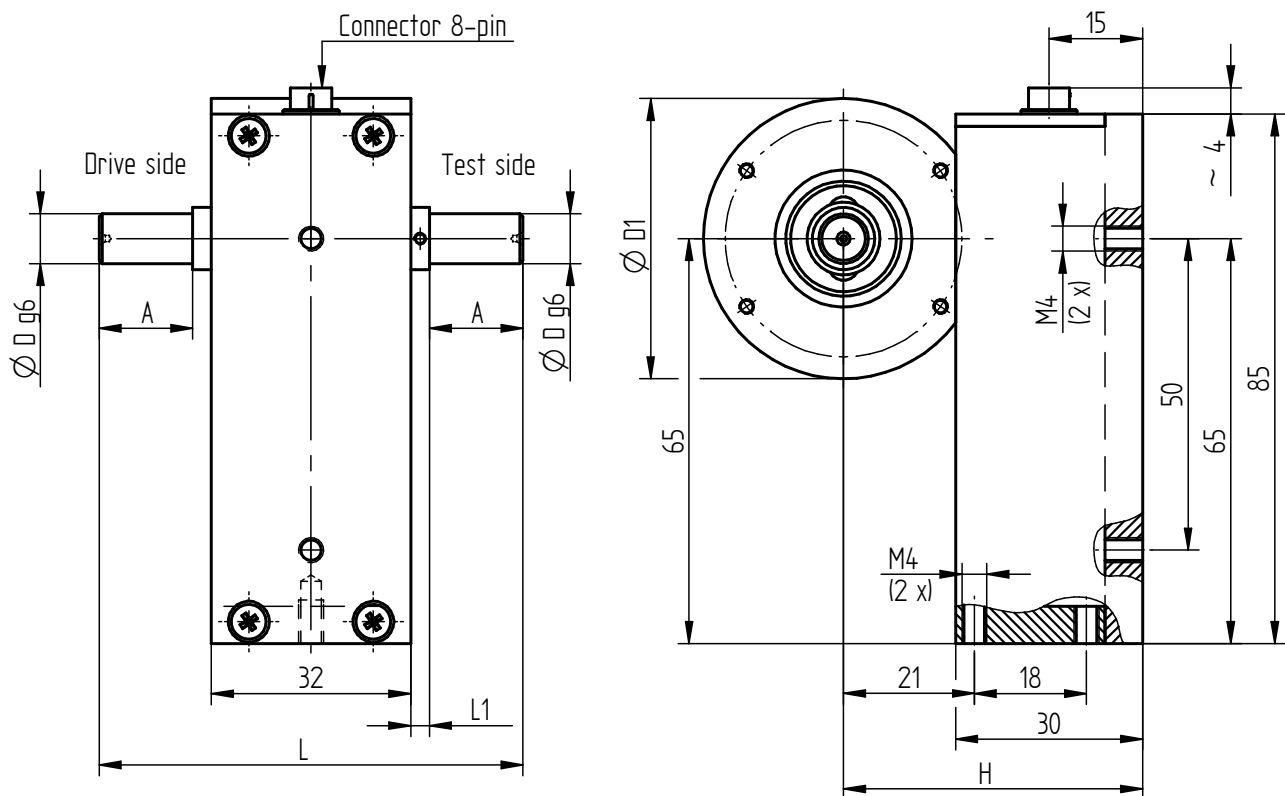

Nominal Torque [N·m]	Dimensions [mm]						Weight [kg]
	ØD	ØD1	A	L	L1	H	
0.005/0.01	4	45	5	48	3	48	0.3
0.02/0.05/0.1/0.2/0.5/1	6	45	7	52	3	48	0.3
2/5	8	45	15	68	3	48	0.3
10	10	45	15	68	3	48	0.3
20/50/100/150	18	59.5	36	122	9	53	0.6

Connection Assignment

8-pin	DR-2500	Series 711
Pin 1	Supply (+)	12 ... 28VDC
Pin 2	Supply (GND)	0V
Pin 3	Signal (+)	±5V (±10V)
Pin 4	Signal (GND)	0V
Pin 5	Control signal	L <2.0V; H >3.5V
Pin 6	Signal speed, optional	5V TTL
Pin 7	NC	-
Pin 8	NC	-
	Housing	Shield

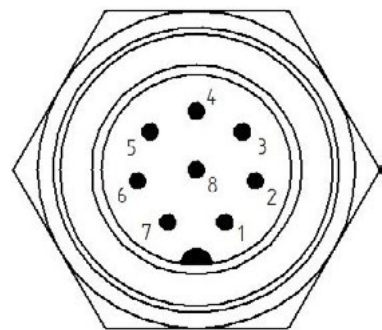

Technical Data acc. to VDI/VDE/DKD 2639

Torque Sensor DR-2500		
Nominal torque M_{nom}	N·m	0.005 ... 150
Accuracy class	% M_{nom}	0.1
Relative repeatability error in unchanged mounting position b'	% M_{nom}	±0.02
Rated range of supply voltage	VDC	12 ... 28
Current consumption	mA	≤60
Output signal	V	±5
Control signal excitation	V	L <2.0; H >3.5
Sample rate	kSample/s	10
Electrical connection		8-pin series 711
Reference temperature T_{ref}	°C	23
Rated temperature range	°C	5 ... 45
Operating temperature range	°C	0 ... 60
Storage temperature range	°C	-10 ... 70
Temperature effect on zero signal TK_0	% $M_{nom}/10\text{ K}$	±0.2
Temperature effect on characteristic value TK_C	% $M_{nom}/10\text{ K}$	±0.1
Maximum operating torque M_G (static)	% M_{nom}	150
Torque limit M_{max} (static)	% M_{nom}	200
Breaking torque M_B (static)	% M_{nom}	>300
Permissible oscillation stress when subjected to torque M_{df}	% M_{nom}	70 (peak-to-peak)
Level of protection		IP50

Article-No.	Nominal Torque [N·m]	Limit Speed [min ⁻¹]	Springrate [N·m/rad]	Mass Moment of Inertia [kg·m ²] ¹		Axial Force Limit [N]	Lateral Force Limit [N]
				Drive Side	Test Side		
107606	0.005	20000	4.6E-01	7.5E-07	1.1E-08	35	1
107607	0.01	20000	4.6E-0.1	7.5E-07	1.1E-08	35	1
107428	0.02	30000	3.7E+00	7.6E-07	1.3E-08	35	1
107429	0.05	30000	3.7E+00	7.6E-07	1.3E-08	40	1.1
107430	0.1	30000	1.8E+01	8.6E-07	3.8E-08	43	1.5
107431	0.2	30000	1.8E+01	8.6E-07	3.8E-08	59	2.3
107432	0.5	30000	1.2E+02	8.6E-07	3.8E-08	185	4.2
107433	1	30000	1.2E+02	8.6E-07	3.8E-08	255	7.2
107434	2	30000	6.2E+02	9.1E-07	8.3E-08	520	14
107435	5	30000	6.2E+02	9.1E-07	8.3E-08	520	14
107436	10	30000	1.5E+03	9.8E-07	1.6E-07	900	33
107598	20	20000	7.4E+03	1.2E-05	3.6E-06	2150	62
107599	50	20000	1.1E+04	1.2E-05	3.9E-06	4000	160
107600	100	20000	1.1E+04	1.2E-05	3.9E-06	4000	160
109190	150	20000	1.2E+04	1.2E-05	4.2E-06	5000	220

¹ Without option speed measurement

Options

Article-No.	Description	
103562	Output signal	±10V
107437	Speed measurement, 1x6 impulses	5V TTL

Calibrations

Article-No.	Description	
400676	Linearity diagram in accordance to factory standard	25 % steps
400664	Linearity diagram in accordance to factory standard	10% steps
400961	Proprietary calibration acc. to VDI/VDE 2646	3 steps
400700	Proprietary calibration acc. to VDI/VDE 2646	5 steps
400688	Proprietary calibration acc. to VDI/VDE 2646	8 steps
	DAkkS-Calibration/Standard on request	

Accessories

Electrical Connection

Article-No.	Description
10307	Female cable connector 8-pin series 712
10366	Female angled connector 8-pin series 712
102669	Connection cable, 3 m, with 8-pin female cable connector series 712 and free strands
106082	Connection cable angled, 3 m, with 8-pin female angled connector series 712 and free strands

Amplifiers

Examples of suitable amplifiers for the torque sensor DR-2500:



Further suitable amplifiers you can find on our homepage under <https://www.lorenz-messtechnik.de/english/products/>.